

# Hilo

REFERENCE A/D D/A CONVERTER SYSTEM



## Hilo - Reengineering the Two Channel Converter PRODUCT INTRODUCTION

The new Hilo Reference A/D D/A Converter System reengineers and redefines the concept and functionality of the two-channel converter. It combines the features of a high-performance A/D converter, D/A converter, monitoring system and headphone amplifier. Hilo offers connectivity, performance and control never before available. Newly designed BiLynear™ conversion technology provides industry-leading noise and distortion specifications and unprecedented transparency.

Hilo's unique I/O and signal routing capabilities work well in recording, mixing, and mastering applications. In addition to the primary analog Line In and Line Out connections, Hilo provides Monitor and Headphone outputs. Digital outputs include USB, AES/EBU, S/PDIF coax, S/PDIF optical, and ADAT. To top it off, each output is fed by an independent mix of all input sources courtesy of the 32-channel internal mixer.

Hilo's breakthrough headphone technology adds a world-class headphone amplifier to the mix. It is capable of driving today's low-impedance headphones with extremely low distortion while maintaining accurate inter-channel gain matching.

Hilo is also the first professional two-channel converter with touchscreen operation and monitoring. All control parameters, signal routing and utilities are set up using easy to use menus. Several level meter types are selectable, such as horizontal meters, old-style VU meters and an All I/O option. Other menus allow you to select sample rate, sync source, optical mode, analog trim settings. An innovative Output Routing mix screen allows any input to be routed to any output with complete level and muting control.

The updatable FPGA-based design and versatility of the LCD screen allow Hilo to accommodate enhancements to features, screens, functions, and utilities. The LSlot expansion port provides an upgrade path to future interface protocols as they become available. So the Hilo you buy today will be continually improved and morph into a device that will also meet your needs in the future.



### KEY FEATURES AND SPECIFICATIONS

- Full-featured, ultra high performance A/D D/A converter
- Reference-quality headphone amplifier
- Sophisticated monitoring system with dedicated outputs
- Analog Line Input and Output: balanced XLR with eight standard trim levels
- Monitor output: two channel balanced TRS with volume control supporting 1/2 dB adjustment
- Headphone output: stereo 1/4" phone jack with volume control supporting 1/2 dB adjustment
- AES/EBU and S/PDIF coax output: transformer coupled
- S/PDIF Optical input and output, also supports ADAT I/O
- Touch-screen LCD interface (480 x 272 pixels)
- Latest FPGA technology allows future enhancements and ability to use LCD technology for added metering, diagnostic, control and measurement functions
- Utilizes Lynx Studio Technology's proprietary SynchroLock™ ultra-low jitter sample clock generator
- Powered by standard 110-230V AC power or 9-18 volts DC, allowing the use of standard video battery packs or auto cigarette lighter connections.
- USB 2.0 high-speed interface compatible with Windows and Mac computers
- Designed and manufactured in the USA by Lynx Studio Technology, Inc.

**LYNX STUDIO TECHNOLOGY, INC.**  
(714) 545-4700 [www.lynxstudio.com](http://www.lynxstudio.com) [sales@lynxstudio.com](mailto:sales@lynxstudio.com)

# Ariolo

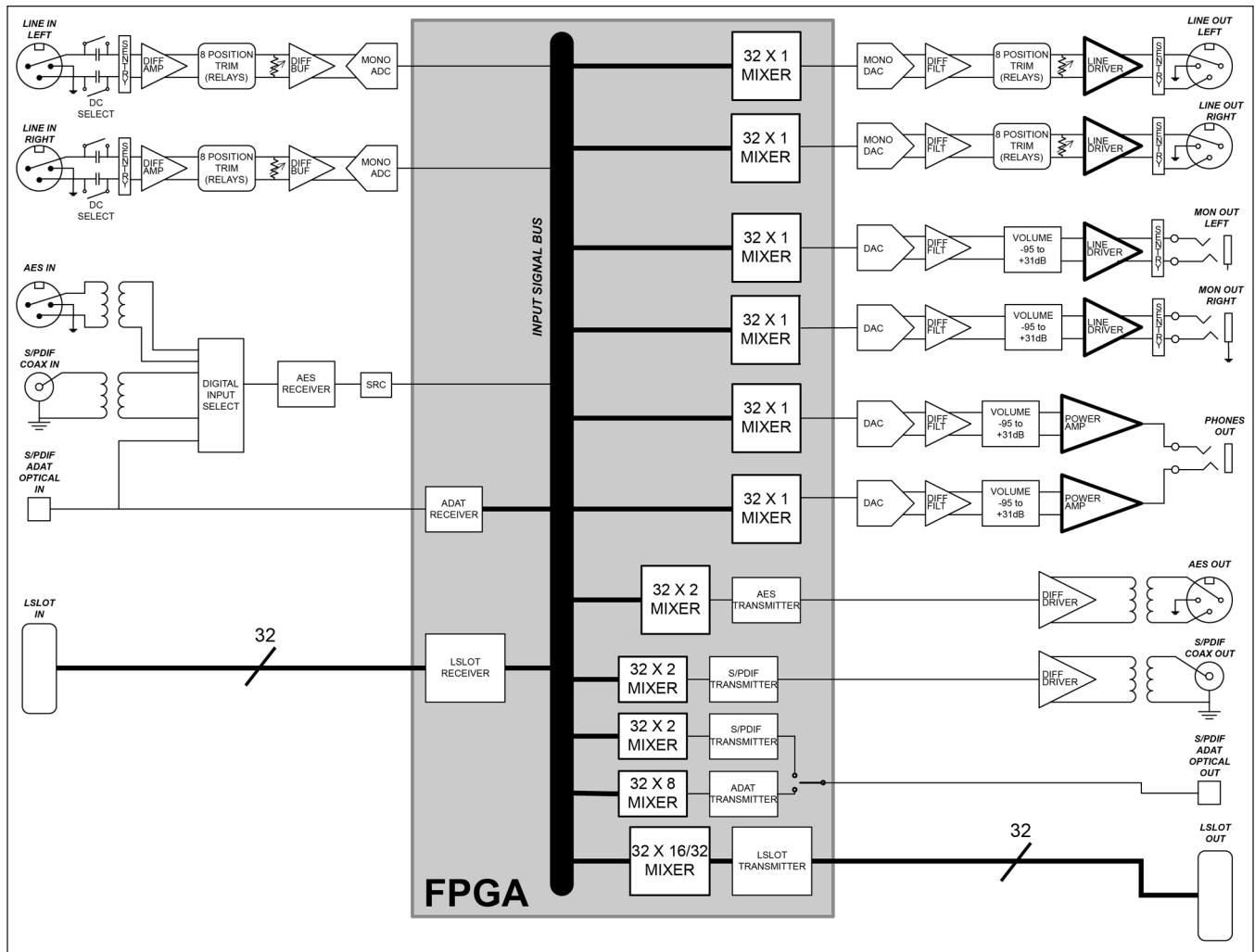

## KEY SPECIFICATIONS

### LINE IN A/D PERFORMANCE

THD+N	-114dB @1kHz, -1dBFS, 20kHz filter
Dynamic Range	121 dB, A-wtd, -60dBFS signal method
FrequencyResponse	± 0.01 dB, 20 – 20kHz
Crosstalk	-140 dB maximum @ 1kHz, -1dBFS signal

### LINE OUT D/A PERFORMANCE

THD+N	-109dB @1kHz, -1dBFS, 20kHz filter
Dynamic Range	121 dB, A-wtd, -60dBFS signal method
Frequency Response	± 0.02 dB, 20 – 20kHz
Crosstalk	-135 dB maximum @ 1kHz, -1dBFS signal

**LYNX STUDIO TECHNOLOGY**  
[www.lynxstudio.com](http://www.lynxstudio.com)

*Lynx*  
**STUDIO  
 TECHNOLOGY**